

# THE PRAIRIE LADY

Rolls-Royce Owners Club - Can-Am Prairie Region



LSRH8 1954 Silver Dawn

Owner: Maurice and Bernice Tims

## Inside this issue

Chairman's Ramblings  
Editor's Notes  
September 2005 HQ report  
October 2005 HQ report  
Brunch at the Palliser  
Upcoming Events  
UPS v. USPS  
Your Shadow's Back End  
For Sale

Newsletter July - September 2005

## Officers and Directors

### Chairman

Robert Manderson  
Calgary, Alberta.  
403-  
[Rob\\_Manderson@](mailto:Rob_Manderson@)



### Treasurer and Membership

Maurice Tims  
Calgary, Alberta.  
403-  
[timsmd@](mailto:timsmd@)

### Secretary

Lorraine Collings  
Calgary, Alberta.  
403-  
[lorraine.collings@](mailto:lorraine.collings@)

### Events

Dawn and Darcy Collings  
Calgary, Alberta.  
403-  
[dawn.collings@](mailto:dawn.collings@)  
[darcy.collings@](mailto:darcy.collings@)

### Terry Murphy

Calgary, Alberta.  
403-  
[terrym@](mailto:terrym@)

### Archives

Howard Lengert  
Calmar, Alberta.  
780-  
[lengert@](mailto:lengert@)

### Newsletter Editor

Christopher M<sup>c</sup>Aviney  
Calgary, Alberta.  
403-  
[tabmow@](mailto:tabmow@)

**LEGAL NOTICE:** The Prairie Lady is the official publication of the Can-Am Prairie Region of the Rolls Royce Owner's Club. It is published four times each year. The Region and editor seek to publish accurate material. Neither the Region nor the Editor assumes any responsibility in the event of claim or loss resulting from this publication however caused. Statements of contributors are their own and do not necessarily reflect Region or Club policy.

Members are encouraged to contribute articles and photographs. Any submissions for publication should be sent to the editor. Please identify individuals and quote the serial number of any car in a photograph.

Advertisements for Rolls-Royce and BENTLEY sales, wants or parts will be published for members at no charge. For car sales please include chassis number and price.

### CONTENTS

Chairman's notes  
Editor's notes  
Upcoming events  
John Lennon's Phantom V  
Region Christmas Party

Copyright 2005

---

## **Chairman's Ramblings**

Well, here we are in early October already, the leaves have nearly all fallen and it is getting close to time to put the toys away for another winter. We haven't been very active this year as a club but the Tech Session at the Doyles' was a highlight for sure.

This is my last Ramble as I have agreed to be RROC Regional Director for the Pacific Northwest again. Unfortunately you haven't totally got rid of me as I will be sharing the job of Social Secretary with George Pope, if the Annual Business Meet feels this would be a good thing. We hope to publish a calendar of events for the next year in the next Prairie Lady.

The Annual Business Meet is scheduled for the 30<sup>th</sup> October at the Black Knight Inn in Red Deer, a return to old haunts for the Business Meet. I felt it best to hold the meet in October as the weather will hopefully co-operate and we can use our cars for the last drive of the year.

As some of you know I was on the recent tour in Washington State and BC. It was a very good tour and went very well. I haven't had time to write up the trip but will hopefully get that done before the next Prairie Lady comes out.

As this is my last Ramble I would like to thank you for allowing me to serve and hope that you will all support Cathy Doyle who has agreed to stand as your next Chair. Maurice Tims is willing to continue as Treasurer and Membership, Chris McAviney as Editor (and a fine job he is doing), Lorraine Collings as Secretary, and George Pope and I as Social Directors. The above slate is of course contingent on the approval of the Annual Meet in Red Deer.

In the meantime change your oil, check your tyre pressure and enjoy the last few drives of 2005.

Yours from the Toy Box

Rob Manderson.

---

## **Editors Notes**

First thing I need to do is apologize for this edition of the The Prairie Lady being late. I have been busy with various personal matters and our esteemed Chairman has sent his ramblings to my old email address for the second time so I thought I would embarrass him into correcting my email address by letting everyone know. Rob, I hope you got the (email) message.

Since receiving the September 2005 report from RROC Headquarters, as we well know a second hurricane, Rita, has hit the same area. I am sure all of the Can-Am Region members support the sentiments expressed in the accompanying letter.

On a brighter note, while east bound on Memorial Avenue in Calgary on September 30<sup>th</sup> I spotted what I think was a Bentley S3. I only saw the car from the rear and from a couple of cars back. It was silver over grey, white wall tyres, licence number TBG 111 (I think), and it appeared to be in very good condition. Does this belong to a club member or was it a renegade? Does anyone know the car?

On behalf of all of the region's members I extend a belated welcome to Jan Kankrlik of Bozeman, Montana, as a member of our region. Belated because I was unaware that he had joined our region back in January until I spoke with Thomas Foster, also of Montana, who told me that Jan was wondering why he had not received the newsletter. I immediately contacted Jan and apologized for the oversight then contacted HQ and advised them of their error in not advising us of Jan's membership. I also sent off the most recent copies of *The Prairie Lady* so as to bring Jan up to date.

As you are all aware I, as editor, receive copies of the newsletters from the other regions. Reflecting our move into the 21<sup>st</sup> century those copies now come to me electronically and as you will see in this issue they are an excellent source of articles for our newsletter. I thank authors, Roger Bradley and Dave Sjolund, for their contribution and for saving your editor some work. Having said that I feel it is of the utmost importance that we as a region make our own contribution. In recognition of this obligation I have been inserting a request for articles or ideas at the end of the newsletter as follows:

"Your editor needs ideas and or written articles for *The Prairie Lady*, how about helping out?"

Obviously it was a bad place to insert it because as far as I can tell, based on the response, no-one reads that far! So I have moved it up here in a part of the newsletter that everyone reads. Ideas would be appreciated actual articles would be a godsend and I would be forever indebted for either.

For those with internet access HQ has been scanning the various regional newsletters. You may view these publications on the club website, by going to <http://www.rroc.org/page.asp?SID=1&Page=59> and reviewing the links found there.

The cover photograph is of Maurice Tilms' Silver Dawn. It is in excellent condition and it is interesting to note he has owned it for at least 40 years and for a good portion of those 40 years it was his daily driver. The photograph on the last page is of John and Cathy Doyle's Silver Spirit and it is there because I like the colour and, being the editor, I get to put it in the newsletter if I want.

Christopher M<sup>c</sup>Aviney

---

Editor's note: What follows is the September and October 2005 reports (verbatim) that the RROC sends to the regional directors and editors. I have also included the letter referred to in the September 2005 Report. I think the Executive Director speaks for all of us and I am sure our thoughts and prayers go out to all people affected by the disaster.

## RROC - September 2005 Report

To: Board of Directors

Cc: Region and Affiliate Chairmen & Editors

From: Timothy E. Younes, Executive Director

**Hurricane Katrina:** At the request of Bill Pritchard, National Director from the Southern Delta Region, we have established a new Discussion Forum on our home page, [www.rroc.org](http://www.rroc.org). It is devoted exclusively to communications to and from our members impacted by the aftermath of Katrina. Within hours of its establishment, members were opening up their homes, trailers, and hearts to fellow club members.

One of our members from that area told us that besides water and gas, what they need most is "INFORMATION!!!" Upon receipt of that email, I drafted the attached letter and emailed it to all club members in the Southern Delta area.

**Ad Hoc Panel:** With Board concurrence, a budget for the ad hoc committee was approved. In the prior weeks, they reviewed and analyzed numerous club documents and interviewed several members. Very sadly and most regrettably, two of the three members have suffered greatly in the past week; one from the devastating after effects from Katrina and the other with a significant illness of a partner. Our thoughts and prayers are with them both.

**Website Traffic:** Traffic reached another all time high in August. We received 114,681 hits. In the last two months we received 30% more hits than the average for the first four months in 2005. Last year at this time, the number of website hits was probably far less than 10,000 per month.

**Membership Status:** Membership continues to increase in the RROC. Membership numbers by category are as follows:

	<u>2005</u>	<u>2004</u>
Full	6,468	6,416
Spouse	2,149	2,063

Junior	159	158
Life	324	325
Total	9,100	8,962

Tim Younes

The attachment that came with the report (Ed.)

Dear Southern Delta Member:

Please know that the thoughts and prayers of the club, and your fellow members are with you and your family...

Many of our members have called into HQ, or sent us emails asking how they can help. Also, in the last 24 hours or so, we have finally received some communication from a few members in your area, who thankfully are doing "OK." One of their first requests (besides clean water) was for us to establish a communication link so that fellow members can contact each other, let them know their status and whereabouts, and if at all possible to offer help.

Thus, we have recently established a new category on our Discussion Forum on the club website, [www.rroc.org](http://www.rroc.org). It is called Southern Delta Communications. It is devoted exclusively to communications to and from our members impacted by the aftermath of Katrina. In typical club fashion, within hours of its establishment, members were opening up their homes, trailers, and hearts to fellow club members.

I encourage you to participate in the Discussion Forum. If you have never done so before, and need some assistance, our staff at HQ will be pleased to help you. Call us at 800 879 7762. If email is not your favorite means of communication, and you wish to call us, we will post the information on your behalf.

The tragedy as it appears on our television screens is almost unfathomable, and I cannot imagine some of the horrors many of you are experiencing. Please know that you are not alone and there are many members willing and able to help.

Tim Younes

---

## October 2005 Report

To: Board of Directors

Cc: Region and Affiliate Chairmen & Editors

From: Timothy E. Younes, Executive Director

**Hurricane Katrina:** The new category we established last month on our Discussion Forum at [www.rroc.org](http://www.rroc.org), devoted exclusively to communications to and from our members impacted by the aftermath of Katrina; received thousands of hits in September. More importantly, it served as a wonderful communications tool by and for our Southern Delta members. Also, many club members made immediate and generous offers to help via the Forum. My thanks to all who cared and offered to help.

**Website:** September marked the third consecutive month we exceeded 100,000 hits. We are now investigating how we will implement some e-commerce options, which will not only help club store sales but also generate more interest and traffic to the site.

**Membership Status:** Membership continues to increase in the RROC. Membership numbers by category are as follows:

	<u>2005</u>	<u>2004</u>
Full	6,531	6,473
Spouse	2,177	2,087
Junior	159	159
Life	324	326
Total	9,191	9,045

**Unpaid Members:** The number of new members not renewing their RROC dues this year was the lowest in several years - and by percentage a significant reduction. To achieve such a result next year, national regions and societies must all continue to work together.

**RROC Elections:** The ballot and biography will be mailed by November 4<sup>th</sup>, as per the club bylaws.

**Dues Mailing:** Annual notices for the club, region and society dues are expected to be mailed in the first week on November. Along with the Dues Notice, will be the annual Stores Catalog.

**Greenwich Results:** Final financial results have been held up pending our "discussions" with the Hyatt Hotel, which are far fewer in number and in scope than last year. In fact, I expect to have that concluded within the next 10 days. We conducted a survey of all meet participants and about a third responded. The results, by and from

our members, were very positive. Significant improvement was noted at the Greenwich Meet and a few areas in which we can continue to improve.

**Toronto Visit:** On September 23 & 24, Robin James and I met with Susan & Henry Popp and Ralph Curzon (Co-Chairs of the meet) to review a proposed meet hotel, to review a splendid Judging Field, and to discuss preliminary activities. The Toronto area certainly offers many great meet activities. I look forward to working with them to make it a great event.

**2007 Meet Visit:** The following weekend I traveled to Stevenson, Washington to meet with the Meet Co-Chairs, Dave Pass and Dick Tilden – and their committee. What a gorgeous site! It is certain to be a memorable event.

**Iroquois Region:** The members of the Iroquois Region are honoring John Utz, long time club member, by planting a tree in his honor at HQ on Friday October 14, 2005. The ceremony is scheduled to coincide with a Tech Session at HQ.

Tim Younes



#### **BRUNCH AT THE PALLISER HOTEL, CALGARY, SEPTEMBER 18, 2005**

In attendance was Jonathon Llyod (top right) owner of SRH14026 a 1972 Silver Shadow saloon, John and Cathy Doyle (top left) owners of SAF-12987 a 1985 Silver Spirit Saloon, myself and my partner, Zelma Kiss (bottom left) owners of GCJ17 a 1935 20/25 Barker Saloon. Although the number that attended was disappointing I found the company and discussion to be very pleasant and interesting. I think between us we solved most of the problems of the world with some thoughts left over. It was a pleasure to meet Jonathon, a member I knew only by an entry in the membership



list until September 18. For those of you that did not attend you missed an excellent brunch with excellent company, John even let us take a photograph of him.

---

## UPCOMING EVENTS

### CLUB EVENTS

October 30<sup>th</sup> Annual Business Meeting at the Black Knight Inn in Red Deer

December TBA, Regional Christmas Party, location TBA

For more information on any of the above RROC Regional Events, please contact :  
Terry Murphy & Marianne Maurer or Dawn & Darcy Collings  
(403) (403)  
terryjmurphy@ darcy.collings@

---

Editors note: The following article was taken verbatim from the April 2005, 23rd issue, of The St. Lawrence Lady. I have had the experience of purchasing a part from a vendor in the U.S. and then being charged more for the shipping than the amount I paid for the part so when I came across this article I felt a need to share it with our region. (Ed.)

### UPS or USPS By Roger Bradley

Recently I had an alloy wheel shipped from the USA to my home in Montreal. Options were to ship either by United Parcel Service (UPS) or by United States Postal Service (USPS). The following are the costs associated with each option.

One Box, size 20" x 20" x 12", weight 20lbs, value \$85 US (\$105.40 CDN at 1.24)

#### UPS Costs (quoted by a UPS agent)

Ground delivery, about 1 week door to door.

Prepaid shipping: \$27.00 US

Cash on delivery costs in \$CDN:

10% duty:	\$10.54
7% GST:	\$ 8.11
7.5% PST:	\$ 9.30
Brokerage Fee:	\$28.30
Brokerage Collection Fee:	\$ 4.25
Disbursement Fee:	\$ 5.85

Total UPS costs: \$27.00 US + \$66.35 CDN = \$99.83 CDN

## USPS Costs:

Ground delivery, 2 to 4 weeks door to door quoted, actually took 17 days.

Prepaid postage	\$23.30 US
Cash on delivery costs in \$CDN	
10% Duty:	\$ 0.00 (duty free item)
7% GST:	\$ 7.38
7.5% PST:	\$ 8.46
Handling Fee:	\$ 5.00

Total USPS costs: \$23.30 US + 20.84 CDN = \$49.73 CDN. No prize for guessing which method I always use.

Editor's note: The item listed under UPS as a "Disbursement Fee" is actually the amount that the Canadian Government charges as a handling fee. It is the same fee as listed under the USPS as a "Handling Fee". The Canadian Government charges a \$5.00 CDN handling fee to process an item through customs, UPS adds GST and PST to that fee then passes that cost along as a disbursement. Also of note is the 10% Duty paid by UPS on a duty free item, UPS then calculates the GST and PST based on the cost of the item and the "duty". The other point to note is that there is, of course, no PST in Ralph's World (for the non-Albertans this refers to our own King Ralph, the Premier of Alberta).

---

## **Your Shadow's Back End**

By Dave Sjolund

There are four areas in the back end of the Shadow that you can explore that will probably save you time, money, and may prevent a failure on the road to an important event!

**Battery** – Most Shadow owners know that the battery is in the trunk, but do you know what size it is, when it was serviced and how old it is? The battery should be size #27,



Figure 1

which is probably not available if you have a failure on the road. Sure, a smaller battery can be put in the battery box, but it will not have the starting power or the reserve energy, should you need it, that the "correct" battery has. The smart approach is to clean the area between the battery posts and the terminals once a year as most batteries really do not fail. There is a poor connection in this area and when "they" install a new battery, "they" can clean the terminals and a \$0 solution costs \$100. Also, if required, the battery should be filled with water. Finally, at a maximum of six years, I would

suggest that you get a new #27 battery installed. (See figure 1.)

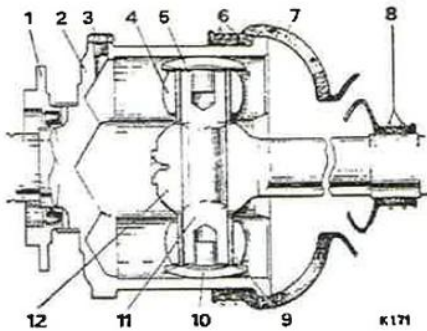

**Half-Shaft Ball and Trunnion Joint**

- 1 Final drive side housing
- 2 Ball and trunnion joint body
- 3 Drain plug
- 4 Needle roller race
- 5 Adjusting washer
- 6 Seal clip
- 7 Joint seal
- 8 Seal clip
- 9 Needle rollers
- 10 Trunnion button
- 11 Trunnion pin
- 12 Half-shaft knuckle end

Figure 2

**Trunnion Joints** – Trunnion joints are the devices on both sides of the centre section of the rear end. Unfortunately, neither the Shop nor Owner's Manual specifies that they should be checked periodically for the correct level of 80/90 gear lube. On my cars I found that the right side "loses" its oil after a year. To where I do not know, but it probably goes into the centre section (my rubber boots are new, do not leak, and the axle to the rear wheels is solid steel). The easy way to check the level is to jack a wheel of the ground, install a safety stand and turn the wheel until a ½ in. box wrench can loosen the plug on the joint (**See figure 2.**) Then, turn the axel until the plug is at a 45-degree from pointing down and remove the plug. If oil does not seep out, fill a dispenser (a four ounce size hair treatment bottle will do nicely) with gear lube. Rotate the wheel so the hole is up, insert the bottle tip and squirt the fluid in. Recheck for the correct level and check the other joint. If these joints are "dry" too long the repair is expensive.

**Emergency Brake Pads** – Adjusting the emergency brake pads is easy if you do not read the manuals. They expect you to remove the wheel, adjust the pads until a .002 feeler gage fits between the pads and the shoes. George Colgett told me about a much easier approach! With the emergency brake off, turn the adjuster until the jacked up wheel will not turn, then back off six "clicks" on the adjuster and recheck that the wheel spins. Then do the other wheel. This works well. (**See figure 3.**)

**Air in the Master Cylinder System** – A couple of mechanics and I have found it difficult to get the air out of the master cylinder system in the pre-1977 Shadows. The Shop and Owner's Manual have different bleeding procedures which indicate to me that the "correct" technique to achieve a firm and high pedal is indeterminate. When I bled the brakes as you should every couple of years, I could only get the pedal to half and it had been higher when I started. Because I had the rear wheel of for another reason, I looked at the rear brake pads and thought about how to get the air out of the lines and/or callipers. I decided to push the callipers in all the way on both wheels. My theory was that the volume of fluid in the callipers was greater than the volume of the lines back to the master cylinder and

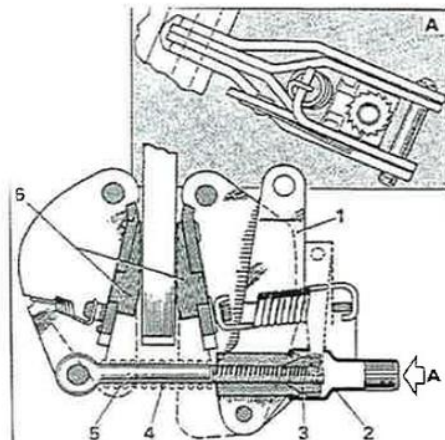

**Hand Brake Pad Mechanism**

- 1 Operating lever
- 2 Adjusting ratchet seal
- 3 Ratchet nut
- 4 Reaction rod spring
- 5 Reaction rod
- 6 hand brake pads and back plates

Inset view on arrow A, rubber boot removed.

Figure 3

up to the reservoir. Thus, any air in the system would be pushed back into the reservoir and rise out of the system through the fluid in the reservoir. Then, I could just push the pedal a few times and the entire system would have only fluid in it. It worked best when I temporarily installed very thin brake pads and elevated the bleed line above the valve.

---



SAF-12987 1985 Silver Spirit saloon

Owners: Kathy and John Doyle

---

**FOR SALE** (not John & Cathy's car)

3 off - Part # UE44052, air filters; 4 off – oil filters for V8 RR engines; 1 off – case of Castrol Brake Fluid RH#363; 1 off – set of shop manuals from 1955 to 1989 (missing 1980 to 1984). The lot - \$3000.00. Contact: Reg Collings

If you wish to advertise items for sale please contact Christopher M<sup>c</sup>Aviney. Advertisements for cars should include the serial number and price. Photographs can be included if supplied in digital JPEG format.



Copyright 2005